



Engineering Excellence!

Reno A & E
 4655 Aircenter Circle
 Reno, NV 89502-5948 USA
 Telephone: (775) 826-2020
 Fax: (775) 826-9191
 Website: www.renoae.com
 E-mail: contact@renoae.com



ADDITIONAL
 OPERATING INSTRUCTIONS FOR

Model AX2DLXR Series

TWO CHANNEL LOOP DETECTOR

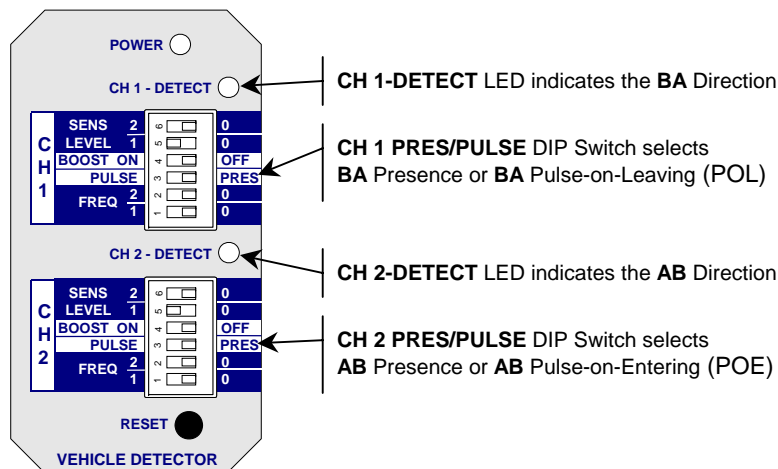

I. General:

This document is provided as a supplement to the Model AX2 and AX2DL Series Operating Instructions. The Model AX2DLXR is a two channel, directional logic detector with four relay outputs that provide the following output functions.

- AB Presence or AB Pulse-on-Entering (POE).
- AB Pulse-on-Leaving (POL).
- AB Backup Pulse.
- BA Presence or BA Pulse-on-Leaving (POL).

AB Direction

AB direction is determined by a vehicle traveling from the loop connected to Channel 1 (*A* Loop) to the loop connected to Channel 2 (*B* Loop). AB Presence or AB Pulse-on-Entering (POE) is indicated by the Channel 2 **DETECT** LED and the closure of the AB Relay. AB Presence or AB POE is selected by means of the Channel 2 Presence / Pulse DIP switch. When the vehicle enters the *B* loop, and is still over the *A* loop, AB Presence will maintain the relay closure as long as the vehicle remains over the *B* loop. AB Pulse-on-Entering will generate a single 250 millisecond pulse output for each vehicle entering the *B* loop. When the vehicle leaves the *B* loop, the detector checks the *A* loop. If the *A* loop is empty, the AB POL Relay will output a single 250 millisecond pulse. If the *A* loop is occupied, the output of the AB POL Relay will be delayed until the assumed second vehicle leaves the *B* loop. If the *A* loop is still occupied, the AB POL Relay will output a single 250 millisecond pulse. If the *A* loop is empty, the AB POL Relay will output two 250 milliseconds pulse outputs with 250 milliseconds between each pulse. If the vehicle leaves the *B* loop and backs out over the *A* loop, the AB Backup Relay will output a single 250 millisecond pulse. If there is an AB POL pulse stored in the detector, it will be cancelled.

BA Direction

BA direction is determined by a vehicle traveling from the loop connected to Channel 2 (*B* Loop) to the loop connected to Channel 1 (*A* Loop). BA Presence or BA Pulse-on-Leaving (POL) is indicated by the Channel 1 **DETECT** LED and the closure of the BA Relay. BA Presence or BA POL is selected by means of the Channel 1 Presence / Pulse DIP switch. BA Presence will maintain the relay closure as long as the vehicle remains over the *A* loop. BA Pulse-on-Leaving will generate a single 250 millisecond pulse output for each vehicle leaving the *A* loop when traveling in the BA direction.

II. Indicators and Controls:

When a vehicle enters the first loop, the channel **DETECT** LED corresponding to that loop will flash at a rate of 250 milliseconds on / 25 milliseconds off. This flash rate will continue as long as the vehicle is over the loop detection area. This feature provides an indication that the vehicle has been detected to assist the user in setting the appropriate sensitivity level.

III. Pin Connections:

Pin	Wire Color	Connector 1 Function	Connector 2 Function
1	Black	AC Line / DC +	No Connection
2	White	AC Neutral / DC Common	No Connection
3	Orange	AB (POL) Relay, Normally Open (N.O.)	AB (Backup) Relay, Normally Open (N.O.)
4	Green	No Connection	No Connection
5	Yellow	BA Relay, Common	AB Relay, Common
6	Blue	BA Relay, Normally Open (N.O.)	AB Relay, Normally Open (N.O.)
7	Gray	Channel 1 Loop	Channel 2 Loop
8	Brown	Channel 1 Loop	Channel 2 Loop
9	Red	AB (POL) Relay, Common	AB (Backup) Relay, Common
10	Violet, or Black / White	BA Relay, Normally Closed (N.C.)	AB (Backup) Relay, Normally Closed (N.C.)
11	White / Green or Red / White	AB (POL) Relay, Normally Open (N.O.)	AB Relay, Normally Closed (N.C.)

Notes: AB and BA Outputs can be factory configured as Fail-Secure (no output signal on power failure or loop failure) or Fail-Safe (output signal on power failure or loop failure). AB (POL) and AB (Backup) Outputs are configured as Fail-Secure.

POL = Pulse-on-Leaving

Please refer to the Model AX2 and AX2DL Operating Instructions for all other details.



Engineering Excellence!

Reno A & E
 4655 Aircenter Circle
 Reno, NV 89502-5948 USA
 Telephone: (775) 826-2020
 Fax: (775) 826-9191
 Website: www.renoae.com
 E-mail: contact@renoae.com



ADDITIONAL
 OPERATING INSTRUCTIONS FOR

Model AX2DLXR Series TWO CHANNEL LOOP DETECTOR

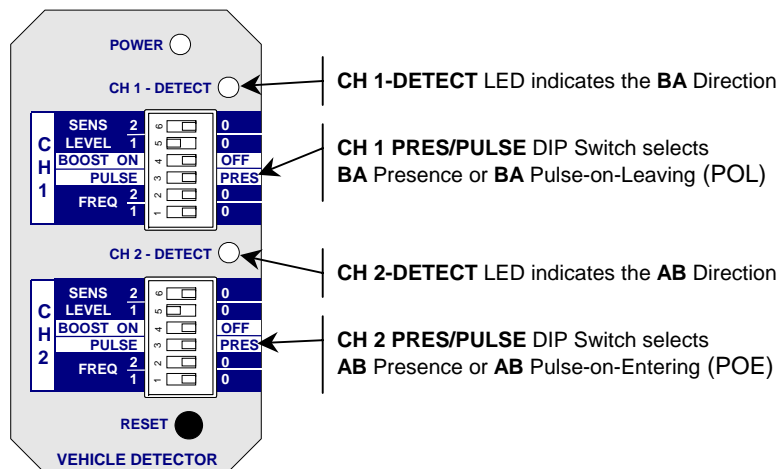

I. General:

This document is provided as a supplement to the Model AX2 and AX2DL Series Operating Instructions. The Model AX2DLXR is a two channel, directional logic detector with four relay outputs that provide the following output functions.

- AB Presence or AB Pulse-on-Entering (POE).
- AB Pulse-on-Leaving (POL).
- AB Backup Pulse.
- BA Presence or BA Pulse-on-Leaving (POL).

AB Direction

AB direction is determined by a vehicle traveling from the loop connected to Channel 1 (*A* Loop) to the loop connected to Channel 2 (*B* Loop). AB Presence or AB Pulse-on-Entering (POE) is indicated by the Channel 2 **DETECT** LED and the closure of the AB Relay. AB Presence or AB POE is selected by means of the Channel 2 Presence / Pulse DIP switch. When the vehicle enters the *B* loop, and is still over the *A* loop, AB Presence will maintain the relay closure as long as the vehicle remains over the *B* loop. AB Pulse-on-Entering will generate a single 250 millisecond pulse output for each vehicle entering the *B* loop. When the vehicle leaves the *B* loop, the detector checks the *A* loop. If the *A* loop is empty, the AB POL Relay will output a single 250 millisecond pulse. If the *A* loop is occupied, the output of the AB POL Relay will be delayed until the assumed second vehicle leaves the *B* loop. If the *A* loop is still occupied, the AB POL Relay will output a single 250 millisecond pulse. If the *A* loop is empty, the AB POL Relay will output two 250 milliseconds pulse outputs with 250 milliseconds between each pulse. If the vehicle leaves the *B* loop and backs out over the *A* loop, the AB Backup Relay will output a single 250 millisecond pulse. If there is an AB POL pulse stored in the detector, it will be cancelled.

BA Direction

BA direction is determined by a vehicle traveling from the loop connected to Channel 2 (*B* Loop) to the loop connected to Channel 1 (*A* Loop). BA Presence or BA Pulse-on-Leaving (POL) is indicated by the Channel 1 **DETECT** LED and the closure of the BA Relay. BA Presence or BA POL is selected by means of the Channel 1 Presence / Pulse DIP switch. BA Presence will maintain the relay closure as long as the vehicle remains over the *A* loop. BA Pulse-on-Leaving will generate a single 250 millisecond pulse output for each vehicle leaving the *A* loop when traveling in the BA direction.

II. Indicators and Controls:

When a vehicle enters the first loop, the channel **DETECT** LED corresponding to that loop will flash at a rate of 250 milliseconds on / 25 milliseconds off. This flash rate will continue as long as the vehicle is over the loop detection area. This feature provides an indication that the vehicle has been detected to assist the user in setting the appropriate sensitivity level.

III. Pin Connections:

Pin	Wire Color	Connector 1 Function	Connector 2 Function
1	Black	AC Line / DC +	No Connection
2	White	AC Neutral / DC Common	No Connection
3	Orange	AB (POL) Relay, Normally Open (N.O.)	AB (Backup) Relay, Normally Open (N.O.)
4	Green	No Connection	No Connection
5	Yellow	BA Relay, Common	AB Relay, Common
6	Blue	BA Relay, Normally Open (N.O.)	AB Relay, Normally Open (N.O.)
7	Gray	Channel 1 Loop	Channel 2 Loop
8	Brown	Channel 1 Loop	Channel 2 Loop
9	Red	AB (POL) Relay, Common	AB (Backup) Relay, Common
10	Violet, or Black / White	BA Relay, Normally Closed (N.C.)	AB (Backup) Relay, Normally Closed (N.C.)
11	White / Green or Red / White	AB (POL) Relay, Normally Open (N.O.)	AB Relay, Normally Closed (N.C.)

Notes: AB and BA Outputs can be factory configured as Fail-Secure (no output signal on power failure or loop failure) or Fail-Safe (output signal on power failure or loop failure). AB (POL) and AB (Backup) Outputs are configured as Fail-Secure.

POL = Pulse-on-Leaving

Please refer to the Model AX2 and AX2DL Operating Instructions for all other details.