

# Model T-400

## Loop Detector Operations Manual

Four Channel DIP Switch Programmable Inductive Loop Vehicle  
Detector

This manual contains technical information for the

### Model T-400 Loop Detector

pn 889-2012-01 Revision: April 2020





THE FOLLOWING PRODUCT WAS DESIGNED, INSPECTED, TESTED AND  
MANUFACTURED IN THE USA BY EBERLE DESIGN, INC. IN PHOENIX, ARIZONA.

INFORMATION CONTAINED HEREIN IS PROPRIETARY TECHNICAL INFORMATION OF  
EBERLE DESIGN, INC. PUBLICATION, REPRODUCTION OR USE IN WHOLE OR PART IS  
NOT PERMITTED EXCEPT UNDER TERMS AGREED UPON IN WRITING. ALL  
REGISTERED TRADEMARKS OF EBERLE DESIGN INC. ARE UNDER  
© COPYRIGHT

**MAINTENANCE NOTE**

**IT IS AN EBERLE DESIGN, INC. RECOMMENDATION THAT EACH UNIT BE TESTED  
AT LEAST ANNUALLY TO ENSURE COMPLIANCE WITH FACTORY  
SPECIFICATIONS AND MEETS PROPER OPERATIONAL STANDARDS. THE  
RESULTS OF THIS TESTING WILL BE DOCUMENTED.**



# Model T-400 Operations Manual

## Table of Contents

---

---

<b>Section 1 General Description</b> .....	<b>1</b>
<b>Section 2 General Characteristics</b> .....	<b>2</b>
2.1 Loop Frequency .....	2
2.2 Presence / Pulse Mode .....	2
2.3 Sensitivity .....	2
2.4 Audible Detect Signal .....	2
2.5 Test Mode .....	2
<b>Section 3 Specifications</b> .....	<b>3</b>
3.1 Physical.....	3
3.2 Electrical.....	3
3.3 Operational .....	3
3.4 Table: Sensitivity, $-\Delta L/L$ , and Typical Response Time.....	4
3.5 Table: Default Settings (Front Panel Mounted DIP Switch) .....	5
3.6 Table: Pin Assignments .....	5
<b>Section 4 User Interface</b> .....	<b>6</b>
<b>Section 5 Installation and Set-Up</b> .....	<b>7</b>
5.1 Front Panel Programming DIP Switches.....	7
5.2 Front Panel Mounted Pushbutton – Audible Detect Signal (Buzzer).....	8
5.3 Front Panel Mounted Pushbutton – Detector Reset.....	8
5.4 PC Board Mounted Jumper – Test Mode .....	8
5.5 Loop Fail Indications .....	8
5.6 Resetting the Detector .....	8
<b>Section 6 Block Diagram</b> .....	<b>9</b>
<b>Section 7 Theory of Operation</b> .....	<b>10</b>
<b>Section 8 Maintenance and Troubleshooting</b> .....	<b>12</b>
8.1 Troubleshooting Power Problems .....	12
8.2 Troubleshooting Loop Fail Problems .....	13
8.3 Troubleshooting Intermittent Loop Fail Problems .....	14
8.4 Troubleshooting Intermittent Detector Lock-Ups .....	14
8.5 Test Mode Operation .....	14
8.6 Things to Know About Loops.....	18



## Section 1 General Description

This Operation Manual was written for people installing, operating, and troubleshooting Reno A & E Model T-400 inductive loop vehicle detectors. The Model T-400 inductive loop vehicle detector is a scanning, four channel, shelf-mount type loop detector. The Model T-400 is designed to meet or exceed the NEMA Standards TS 1-1989.

The Model T-400 uses a microcontroller to monitor and process signals from four separate loop / lead-in circuits. The operation of each channel is independently programmed with a front panel mounted six-position DIP switch module to provide the following selections:

Seven Sensitivity Levels (- $\Delta$ L/L%) and OFF.

Presence or Pulse Mode.

Four Frequency Selections.

The Model T-400 sequentially excites the four loop circuits. This eliminates adjacent loop fields from coupling together (crosstalk) when the loops are connected to the same detector. Each time the loop circuit is activated, loop data is obtained and recorded. The data is compared to previous samples for the amount and rate of change. A slow rate of change, as is the case with environmental drift, is continuously tracked. If a rapid change exceeds a threshold set by the sensitivity level, the output is activated.

If the total inductance of the loop input network goes out of the range specified for the detector, or rapidly changes by more than  $\pm 25\%$ , the channel will enter the programmed Fail-Safe mode of operation. Fail-Safe operation, generates a continuous *CALL* output state as long as a loop failure condition exists.

Each channel has a single, dual color (green / red) Detect / Fail LED indicator. The LED provides an indication of the channel's output state and loop failure conditions. Output state conditions are indicated when the Detect / Fail LED is illuminated in a green state. Loop failure conditions are indicated when the Detect / Fail LED is illuminated in a red state.

The Detect / Fail LED will illuminate (red) to indicate that an Open Loop Failure or an inductance change condition of greater than  $+25\%$  exists. The Detect / Fail LED will flash (red) at a one Hz rate to indicate a Shorted Loop Failure or an inductance change condition of greater than  $-25\%$  exists. Either indication will continue for as long as the loop failure exists. If the loop self-heals, the channel will resume operation in a normal manner, except the Detect / Fail LED will flash (red) at a rate of three 50 millisecond flashes per second, thus providing an alert that a loop fail condition has occurred. Any prior loop failure indication will continue until the detector is manually reset or power is removed.

The Detect / Fail LED will illuminate (green) to indicate a vehicle presence in the loop area. If a prior Loop Failure condition has occurred and detection occurs, the Detect / Fail LED will flash (red) at a rate of three 50 millisecond flashes per second followed by a single 750 millisecond flash (green). This prior Loop Failure indication will continue until the detector is manually reset or power is removed.

In addition, the Reno A & E Model T-400 has a Test Mode that uses the microcontroller to verify the proper operation of the detector's controls and indicators (switches and LEDs). Each channel's loop oscillator circuit can also be tested to verify the correct frequency range in each of the four frequency selections.

The Model T-400 Series is comprised of the following detectors:

Model T-400-R	For NEMA TS-1 applications calling for a four channel, 120 volt AC, shelf mount detector with relay outputs.
Model T-400-SS	For NEMA TS-1 applications calling for a four channel, 120 volt AC, shelf mount detector with solid state outputs.
Model T-400-R-240A	For NEMA TS-1 applications calling for a four channel, 240 volt AC, shelf mount detector with relay outputs.
Model T-400-SS-240A	For NEMA TS-1 applications calling for a four channel, 240 volt AC, shelf mount detector with solid state outputs.

## Section 2 General Characteristics

### 2.1 LOOP FREQUENCY

There are four (4) selectable loop frequency settings (normally in the range of 20 to 100 kilohertz) for each channel. The actual loop operating frequency is a function of the loop / lead-in network and the components of the loop oscillator circuit. Adjacent loops connected to different detectors may crosstalk and require changing of the operating frequency of one of the loop circuits. If crosstalk is a problem, select another loop frequency for stable operation. The four frequency selections are controlled with two DIP switches (labeled 1 and 2) on each of the four front panel mounted six-position DIP switch modules.

*NOTE: The detector channel must be RESET after changing the frequency setting.*

### 2.2 PRESENCE / PULSE MODE

Two modes of operation for each channel of the detector are available. Presence or Pulse Mode is selected by setting the state of a DIP switch (labeled 3) on each of the four front panel mounted six-position DIP switch modules.

**PRESENCE MODE:** Provides a Call hold time of at least four minutes (regardless of vehicle size) and typically one to three hours for an automobile or truck. This is the factory default setting and the most common setting.

**PULSE MODE:** An output Pulse of  $125 \pm 10$  milliseconds duration is generated for each vehicle entering the loop detection zone. Each detected vehicle is instantly tuned out if it remains in the loop detection zone longer than two seconds. This enables detection of subsequent vehicles entering the loop detection zone. After each vehicle leaves the loop detection zone, the channel resumes full sensitivity within one second.

*NOTE: Changing the Presence / Pulse switch setting of an individual channel will RESET that channel.*

### 2.3 SENSITIVITY

There are seven (7) selectable sensitivity levels plus OFF for each channel. The sensitivity levels are designed so that a one level increase actually doubles the sensitivity and a one level decrease halves the sensitivity. The seven sensitivity levels and OFF setting are selected via three DIP switches (labeled 4, 5, and 6) on each of the four front panel mounted six-position DIP switch modules. (See Section 3.4 for actual detection levels and response times for each sensitivity level.)

*NOTE: Changing the sensitivity level setting of an individual channel will RESET that channel.*

### 2.4 AUDIBLE DETECT SIGNAL

The push button on the front panel labeled **BUZZER** is used to enable an Audible Detect Signal. When this feature is enabled (on), an audible signal will be activated whenever the detection zone for the selected channel is occupied. The audible signal indicates actual occupancy of the loop detection zone.

### 2.5 TEST MODE

Test Mode uses the microcontroller to verify the proper operation of the detector's controls and indicators (switches and LEDs). Each channel's loop oscillator circuit is also tested to verify the correct frequency range in each of the four frequency selections.



## Section 3 Specifications

### 3.1 PHYSICAL

WEIGHT: 34.0 oz (963.9 gm).

SIZE: 6.45 inches (16.38 cm) high x 2.50 inches (6.35 cm) wide x 6.35 inches (16.13 cm) deep excluding connector. Connector adds .675 inches (1.71 cm) to depth measurement.

OPERATING TEMPERATURE: -40°F to +180°F (-40°C to +82°C).

CIRCUIT BOARD: Printed circuit boards are 0.062 inch thick FR4 material with 2 oz. copper on both sides and plated through holes. Circuit board and components are conformal coated with polyurethane.

CONNECTOR: MS 3102A-22-14P 19 pin male. See Section 3.6 for pin assignments.

### 3.2 ELECTRICAL

POWER: 89 to 135 VAC, 50/60 Hz, 6 Watts maximum (120 volt AC models). 180 to 270 VAC, 50/60 Hz, 6 Watts maximum (240 volt AC models).

LOOP INDUCTANCE RANGE: 20 to 2000 microhenries with a Q factor of 5 or greater.

LOOP INPUTS: Transformer isolated. The minimum capacitance added by the detector is 0.068 microfarad.

LIGHTNING PROTECTION: Meets and/or exceeds all applicable NEMA TS 1 specifications for transient voltage protection.

RESET: Meets and/or exceeds NEMA TS 1 detector specifications. Each detector channel can be manually reset by momentarily changing any switch position (except the frequency switches). The detector is also reset by pressing the front panel mounted reset push button or by the return of power after a power loss.

RELAY RATING: The relay contacts are rated for 6 Amps maximum, 150 VDC maximum, and 180 Watts maximum switched power.

SOLID STATE OUTPUT RATING: Optically isolated. 30 VDC maximum collector (drain) to emitter (source). 100 mA maximum saturation current. 2 VDC maximum transistor saturation voltage. The output is protected with a 33-volt Zener diode connected between the collector (drain) and emitter (source).

### 3.3 OPERATIONAL

DETECT / FAIL INDICATORS: The detector has one super bright, high intensity, two color (green / red) light emitting diode (LED) per channel to indicate a CALL output and/or the status of any current or prior loop failure conditions. A continuous ON (green) state indicates a CALL output. A continuous ON (red) state indicates that a current open loop failure condition or an inductance change condition of greater than +25% exists. This indication also generates a CALL output. A one Hz (red) flash rate indicates that a current shorted loop failure condition or an inductance change condition of greater than -25% exists. This indication also generates a CALL output. A flash rate of three 50 millisecond (red) flashes indicates a prior loop failure condition. A flash rate of three 50 millisecond (red) flashes followed by a single 750 millisecond (green) flash indicates a prior loop failure condition and a current CALL output (detect state).

If either channel has the audible detect feature activated, that channel's Detect / Fail LED will be illuminated in an orange state for any CALL output condition.

Detect / Fail LED	Meaning
OFF	No Detect / No Loop Failure Condition (No CALL Output)
Solid ON (Green)	Detect (CALL Output)
Solid ON (Orange)	Audible Detect Signal Activated, Detect (CALL Output)
Solid ON (Red)	Open Loop Failure Or Inductance change condition of greater than +25% exists
One Hz flash rate (Red) (50% Duty Cycle)	Shorted Loop Failure Or Inductance change condition of greater than -25% exists
Three 50 ms (Red) flashes per second	Loop Failure condition occurred but no longer exists
Three 50 ms (Red) flashes per second followed by a single 750 ms (Green) flash	Loop Failure condition occurred but no longer exists And Detect (CALL Output)
Three 50 ms (Red) flashes per second followed by a single 750 ms (Orange) flash	Loop Failure condition occurred but no longer exists, Audible Detect Signal Activated, And Detect (CALL Output)

RESPONSE TIME: Meets or exceeds NEMA TS 1 response time specifications. See *Sensitivity, -ΔL/L, & Typical Response Times* table for actual response times.

SELF-TUNING: The detector automatically tunes and is operational within two seconds after application of power or after being reset. Full sensitivity and hold time require 30 seconds of operation.

ENVIRONMENTAL & TRACKING: The detector is fully self-compensating for environmental changes and loop drift over the full temperature range and the entire loop inductance range.

GROUNDING LOOP OPERATION: The loop isolation transformer allows operation with poor quality loops (which may include one short to ground at a single point).

LOOP FEEDER LENGTH: Up to 5000 feet (1500 m) maximum with proper feeder cable and appropriate loops.

LOOP (FAIL) MONITOR: If the total inductance of the channel's loop input network goes out of the range specified for the detector, or rapidly changes by more than ±25%, the channel will immediately enter the Fail-Safe mode of operation. The Fail-Safe mode of operation generates a continuous call during the loop failure. The Detect / Fail LED will provide an indication to identify the type of loop failure condition that exists. A continuous ON (red) state indicates that a current open loop failure condition or an inductance change condition of greater than +25% exists. A one Hz (red) flash rate indicates that a current shorted loop failure condition or an inductance change condition of greater than -25% exists. This will continue as long as the loop fault exists. **However, if the detector is reset, or power is momentarily lost, the detector will return if the loop inductance is within the acceptable range. If any type of loop failure occurs in one (or more) loop(s) in a group of two or more loops wired in parallel, the detector will not respond with a Fail-Safe output following any type of reset. It is essential that multiple loops wired to a common detector channel always be wired in series to ensure Fail-Safe operation under all circumstances.** If the loop self-heals, the detector will resume operation in a normal manner except that the Detect / Fail LED will begin to flash at a rate of three 50 millisecond (red) flashes per second, thus providing an alert that the detector has experienced a prior loop failure condition. During this state, the Detect / Fail LED will also illuminate for 750 milliseconds (green) for a CALL output. The Detect / Fail LED will continue this display pattern indicating the prior loop failure condition and/or detect state until the detector is manually reset or power is removed.

FAIL-SAFE OUTPUTS: A detection output (CALL) is indicated by a closed relay contact (Relay output) or a conducting state (Solid State output). A channel's output defaults to a CALL state for any loop failure condition on that channel or upon loss of power.

### 3.4 TABLE: SENSITIVITY, -ΔL/L, AND TYPICAL RESPONSE TIME

Sensitivity Level	Industry Reference	Switch 4	Switch 5	Switch 6	-ΔL/L Threshold	Response Time
0		OFF	OFF	OFF	OFF	-----
1		ON	OFF	OFF	0.64%	125 ms ±40 ms
2	Low	OFF	ON	OFF	0.32%	125 ms ±40 ms
3		ON	ON	OFF	0.16%	125 ms ±40 ms
4	Normal	OFF	OFF	ON	0.08%	125 ms ±40 ms
5		ON	OFF	ON	0.04%	125 ms ±40 ms
6	High	OFF	ON	ON	0.02%	125 ms ±40 ms
7		ON	ON	ON	0.01%	125 ms ±40 ms

**3.5 TABLE: DEFAULT SETTINGS (FRONT PANEL MOUNTED DIP SWITCH)**

DIP Switch	Function	Setting	Position
1	Frequency	0	OFF
2			OFF
3	Presence / Pulse Mode	Presence	ON
4	Sensitivity	6	OFF
5			ON
6			ON

**3.6 TABLE: PIN ASSIGNMENTS**

Pin	Function (Relay Outputs)	Function (Solid State Outputs)
A	Power, Neutral, 120 /240 VAC	Power, Neutral, 120 / 240 VAC
B	Channel 4 Output, Relay Common	Channel 4 Output, Emitter (Source)
C	Power, Line, 120 /240 VAC	Power, Line, 120 /240 VAC
D	Channel 1 Loop Input	Channel 1 Loop Input
E	Channel 1 Loop Input	Channel 1 Loop Input
F	Channel 2 Loop Input	Channel 2 Loop Input
G	Channel 2 Loop Input	Channel 2 Loop Input
H	Chassis Ground	Chassis Ground
J	Channel 3 Loop Input	Channel 3 Loop Input
K	Channel 3 Loop Input	Channel 3 Loop Input
L	Channel 4 Loop Input	Channel 4 Loop Input
M	Channel 4 Loop Input	Channel 4 Loop Input
N	Channel 1 Output, Relay Normally Open	Channel 1 Output, Collector (Drain)
P	Channel 1 Output, Relay Common	Channel 1 Output, Emitter (Source)
R	Channel 2 Output, Relay Common	Channel 2 Output, Emitter (Source)
S	Channel 2 Output, Relay Normally Open	Channel 2 Output, Collector (Drain)
T	Channel 3 Output, Relay Common	Channel 3 Output, Emitter (Source)
U	Channel 3 Output, Relay Normally Open	Channel 3 Output, Collector (Drain)
V	Channel 4 Output, Relay Normally Open	Channel 4 Output, Collector (Drain)

*NOTE: Relay contact states are shown with power applied, loop(s) connected, and no vehicle(s) present.*

**Section 4 User Interface**

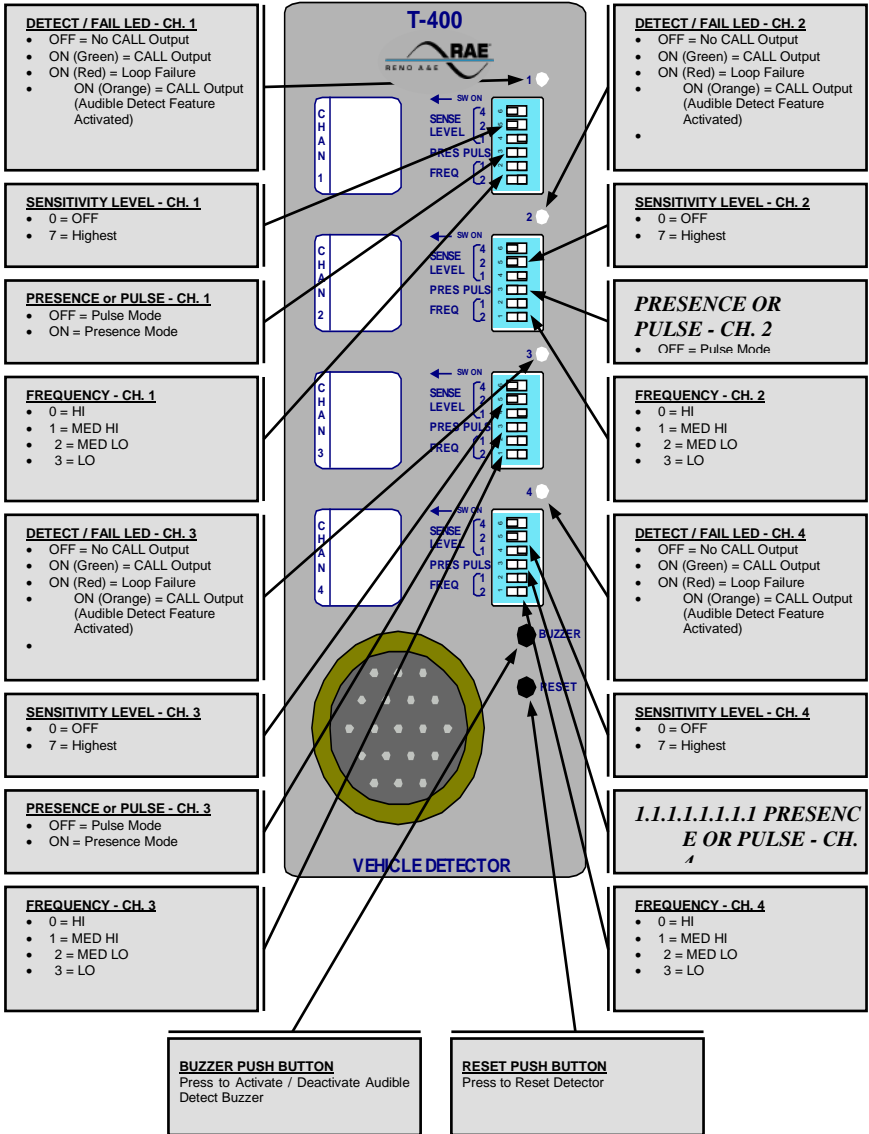

NOTE: There are no internal switches or jumpers to set.

## Section 5 Installation and Set-Up

Each channel has a front panel mounted six-position DIP switch module to control the operation of the channel. The various switches can be set before or after the harness has been connected to the detector. The PRES / PULSE switch can be pre-selected for the desired mode of operation. The SENSE LEVEL and FREQ switches may require adjustment after the harness has been connected. When power is applied to the detector, each channel will automatically tune to the loop circuit and begin operation within two seconds.

Connect the detector to an appropriately wired harness and apply power.

### 5.1 FRONT PANEL PROGRAMMING DIP SWITCHES

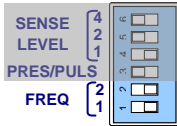

**Frequency:** The Model T-400 detector sequentially activates each channel's loop circuit; so crosstalk between adjacent loops connected to different channels of the same detector is normally not a concern. Adjacent loops connected to different detectors may crosstalk. This may require changing the operating frequency of one of the loop circuits. If crosstalk is a problem, select another loop frequency for stable operation. Each channel of the Model T-400 has four frequency selections that allow altering the resonant frequency of the loop circuit. The four frequency selections are controlled with two switches marked 1 and 2 on the DIP switch module. The values (1 and 2) to the left of the DIP switch are assigned to the switch when the switch is ON. If the switch is OFF, the switch has a value of zero (0). By adding the switch **ON** and **OFF** values, the two switches can combine for values from 0 to 3 that indicate one of the four frequency selections. Use the following table as a reference for the switch selections and frequency settings. The factory default setting of these switches is switch 1 OFF and switch 2 OFF (HI).

*NOTE: After changing the frequency switch setting, it is necessary to reset the channel by momentarily changing one of the other switch positions.*

Frequency	Switch 2	Switch 1	Switch Values
HI *	OFF *	OFF *	0 + 0 = 0 *
MED HI	ON	OFF	1 + 0 = 1
MED LO	OFF	ON	0 + 2 = 2
LO	ON	ON	1 + 2 = 3

\* Factory default setting.



**Presence / Pulse Output Mode:** One of two output modes can be selected for each channel.

**PRESENCE (PRES):** When the switch is in the ON position, Presence Mode is selected. Presence Mode provides a call hold time of at least four minutes (regardless of vehicle size) and typically one to three hours for an automobile or truck.

**PULSE (PULS):** When the switch is in the OFF position, Pulse Mode is selected. Pulse Mode will generate a single 125 millisecond pulse output for each vehicle entering the loop detection zone. Any vehicle remaining in the loop detection zone longer than two seconds will be tuned out providing full sensitivity for the vacant portion of the loop detection zone. Full sensitivity for the entire loop detection zone is recovered within one second following the departure of any vehicle that has occupied the loop detection zone longer than two seconds.

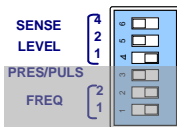

**Sensitivity:** Each detector channel has seven sensitivity levels plus OFF that are selected with three switches marked 4, 5, and 6 on the DIP switch module. The values (1, 2, and 4) to the left of the DIP switch are assigned to each switch when the switch is ON. If the switch is OFF, the switch has a value of zero (0). By adding the switch **ON** and **OFF** values, the three switches can combine for values from 0 to 7 indicating which of the seven sensitivity levels or OFF has been selected for the channel. Choose the lowest sensitivity level that will consistently detect the smallest vehicle that must be detected. Do not use a sensitivity level any higher than necessary. The following table shows the actual sensitivity for each combination of switch settings. The factory default setting of these switches is switch 4 OFF, switch 5 ON, and switch 6 ON (sensitivity level 6,  $-\Delta L/L = 0.02\%$ ).

Sensitivity Level	Industry Reference	Switch 4	Switch 5	Switch 6	-ΔL/L Threshold
0	OFF	OFF	OFF	OFF	N/A
1		ON	OFF	OFF	0.64%
2	Low	OFF	ON	OFF	0.32%
3		ON	ON	OFF	0.16%
4	Normal	OFF	OFF	ON	0.08%
5		ON	OFF	ON	0.04%
6 *	High *	OFF *	ON *	ON *	0.02% *
7		ON	ON	ON	0.01%

\* Factory default setting.

## 5.2 FRONT PANEL MOUNTED PUSHBUTTON – AUDIBLE DETECT SIGNAL (BUZZER)

The push button on the front panel labeled **BUZZER** is used to enable an Audible Detect Signal. When this feature is enabled (on), an audible signal will be activated whenever the detection zone for the selected channel is occupied. The audible signal indicates actual occupancy of the loop detection zone. Only one channel can be turned on at a time. Turning this feature on for one channel automatically turns it off for the other channels. To activate this feature, press the push button. The first time the push button is pressed, a short (50 millisecond) audible signal confirms the activation of the feature for Channel 1. The second time the push button is pressed, two short (50 millisecond) audible signals confirm the activation of the feature for Channel 2. The third time the push button is pressed, three short (50 millisecond) audible signals confirm the activation of the feature for Channel 3. The fourth time the push button is pressed, four short (50 millisecond) audible signals confirm the activation of the feature for Channel 4. To deactivate this feature, press and hold the push button for one second. A long (250 millisecond) audible signal confirms the deactivation of the feature. This feature is automatically disabled 15 minutes after activation or on loss of power.

*NOTE: When operating in Pulse Mode, the audible detect signal will cease once a vehicle has occupied the detection zone for more than two seconds.*

## 5.3 FRONT PANEL MOUNTED PUSHBUTTON – DETECTOR RESET

The push button on the front panel labeled **RESET** is used to reset the detector.

## 5.4 PC BOARD MOUNTED JUMPER – TEST MODE

Test Mode uses the microcontroller to verify the proper operation of the detector's controls and indicators (switches and LEDs). When connected to loops of the appropriate inductance (100 microhenries), each channel's loop oscillator circuit can also be tested to verify the correct frequency range in each of the four frequency selections. Test Mode is selected by placing a shorting jumper (shunt) across the PC Board mounted two-pin header labeled **TEST**. Refer to Section 8.5 for a complete explanation of Test Mode operation.

## 5.5 LOOP FAIL INDICATIONS

The Detect / Fail LED for each channel indicates loop failure problems according to the following table. The Detect / Fail LED is illuminated in a red state to provide an indication of either a current or prior out of tolerance (loop failure) condition. A continuous ON (red) state indicates that a current open loop failure condition or an inductance change condition of greater than +25% exists. A one Hz (red) flash rate indicates that a current shorted loop failure condition or an inductance change condition of greater than -25% exists. If the loop self-heals, the channel will resume operation in a normal manner except that the Detect / Fail LED will begin to flash at a rate of three 50 millisecond (red) flashes per second, thus providing an alert that the channel has experienced a prior loop failure condition.

Detect / Fail LED	Meaning
OFF	No Loop Failure
Solid ON (Red)	Open Loop Failure Or Inductance change condition of greater than +25% exists
One Hz flash rate (Red) (50% Duty Cycle)	Shorted Loop Failure Or Inductance change condition of greater than -25% exists
Three 50 ms (Red) flashes per second	Loop Failure condition occurred but no longer exists

## 5.6 RESETTING THE DETECTOR

Changing the position of any of an individual channel's front panel mounted DIP switches (except the Frequency switches) resets the channel.

The detector is reset by pressing the front panel mounted reset push button or by the return of power after a power loss.

**Section 6 Block Diagram**

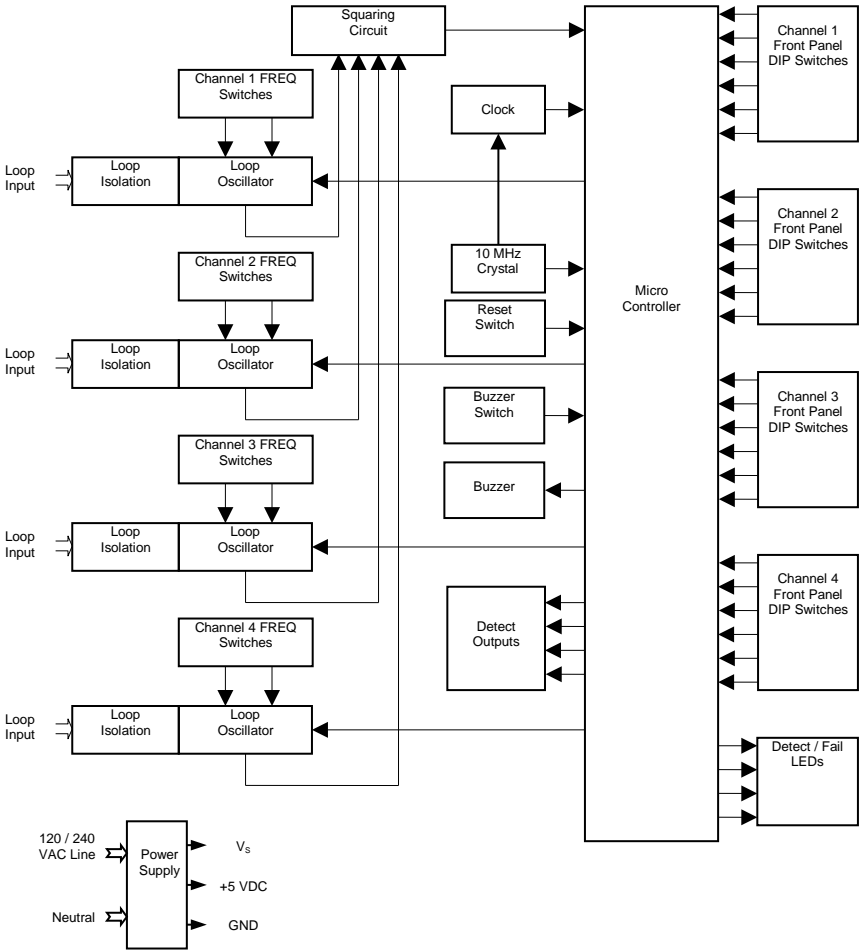

## Section 7 Theory of Operation

The Reno A & E Model T-400 Detector digitally measures changes in the resonant frequency of four independent parallel tuned resonant circuits (loop / lead-in) to determine if a vehicle has entered the detection zones. The detector applies an excitation voltage to each loop circuit resulting in the loop oscillating at its resonant frequency. The current flow in the loop wire creates magnetic fields around the loop wire. When a vehicle passes over the loop area, the conductive metal of the vehicle causes a loading of the loop's magnetic fields. The loading decreases the loop inductance, which causes the resonant frequency to increase. By continuously sampling the loop's resonant frequency, the magnitude and rate of change can be determined. If the frequency change exceeds a selectable threshold (set by the sensitivity settings), the detector will activate an output signal. If the rate of change is slow, typical of environmental drift, the detector will continuously track and compensate for the change. The detector also monitors the loop frequency for out of range conditions such as an opened or shorted loop circuit.

The detector scans the loop / lead-in circuits connected to each detector channel. The scanning method alternates the on and off cycle of each channel's loop circuit such that only one channel's loop circuit is active at a given time. Each channel's oscillator circuit supplies the excitation voltage that is coupled to the loop circuit by a loop isolation transformer. The transformer provides high common mode isolation between the loop and detector electronics, which allows the detector to operate on poor quality loops including a single short to ground. The transformer also limits the amount of static energy (lightning) that can transfer to the detector electronics. A spark gap transient suppression device is connected across the loop inputs to the isolation transformer. This device will dissipate static charges prior to the transformer. The loop input is also filtered for 60-cycle noise. A network of three capacitors is connected to the detector side of the isolation transformer. The capacitors can be switched in or out of the oscillator circuit to shift the frequency of the loop circuit thus providing frequency separation between adjacent loops.

The sine wave from the loop circuit is squared for the microcontroller to digitally measure the period of several cycles. A high-speed clock sets a reference count for the period in a counter. If the frequency increases, the period is shorter and the period count decreases. By comparing the new count with the reference count, a percentage of change can be calculated that indirectly relates to the inductance change. If the magnitude of the change exceeds a selectable threshold (sensitivity setting), the detector activates the output device.

The rate of change is also monitored. Slow rates of change typical of environmental drift are tracked and automatically compensated for. If the total inductance of the loop input network goes out of the range specified for the detector, or rapidly changes by more than  $\pm 25\%$ , the channel will immediately enter the Fail-Safe mode of operation. Fail-Safe operation generates a continuous call output in Presence Mode or Pulse Mode. The Detect / Fail LED will turn ON (red) or flash (red) at a one Hz rate and remain on or continue flashing for as long as the loop failure exists. If the loop self-heals, the channel will resume operation in a normal manner; except the Detect / Fail LED will begin to display a pattern of three red flashes per second, thus providing an alert of a prior Loop Fail condition. The Detect / Fail LED will continue indicating the last loop failure condition until the detector is manually reset or power is removed.

The detector is designed to operate from A.C. power sources providing 120 VAC (Models T-400-R and T-400-SS) or 240 VAC (Models T-400-R-240A and T-400-SS-240A). On board regulators provide regulated voltages so that the detector can safely operate over the full input voltage range of 89 VAC to 135 VAC (Models T-400-R and T-400-SS) or 180 VAC to 270 VAC (Models T-400-R-240A and T-400-SS-240A). The unit is also provided with an external reset capability. When the front panel mounted reset button is pressed, all detector channels are immediately reset. Changing any front panel DIP switch (except the frequency DIP switches) resets the associated channel.

Operating parameters that can be selected by means of the front panel DIP switches are Loop Frequency, Presence / Pulse Mode, and Sensitivity. A front panel mounted push button is used for activation of an audible detect signal. The loop frequency switches are directly connected to the tuning capacitors in the loop oscillator circuits. The settings of the remaining switches are strobed into the microprocessor. The microprocessor provides four output signals; a separate output line for each channel. Each output line drives either a fail-safe optically isolated transistor or a mechanical relay. Solid state output devices provide faster turn ON and turn OFF times thus giving more accurate information when the detector is used in speed and/or occupancy applications. The output signals are connected to four, dual color (green / red), front panel mounted Detect / Fail LEDs. Each LED corresponds to an individual detector channel. The Detect / Fail LEDs are normally extinguished when there are no detect outputs, the loops are in tolerance, and there have been no previous failure conditions. A Detect / Fail LED will be steady ON (green) when a current detect output state exists. A Detect / Fail LED will be steady ON (red) when a current open loop failure or an inductance change condition of more than 25% exists. A Detect / Fail LED will flash at a one Hz rate (red) when a current shorted loop failure or an inductance change condition of less than 25% exists. When a Detect / Fail LED flashes at a rate of three 50 millisecond flashes per second (red), it is an indication that the loop is currently in tolerance, but the detector channel has previously experienced an out of tolerance condition. If a current detect output state exists and a detector channel has previously experienced an out of tolerance condition, the corresponding Detect / Fail LED will flash at a rate of three 50 millisecond flashes per second (red) followed by a single 750 millisecond flash (green). Either of these prior failure Detect / Fail LED flashing conditions will be reset whenever the detector is reset, the channel is reset, or power is interrupted.



The Reno A & E Model T-400 detector is designed and manufactured using the latest available technology in electronic design and manufacturing; thus providing the highest possible performance and reliability. Once properly installed a Reno A & E loop detector will provide years of trouble free operation.

## Section 8 Maintenance and Troubleshooting

The Reno A & E Model T-400 Detector requires no maintenance. If you are having problems with your Model T-400 detector, use the troubleshooting table below to help determine the cause of the problem.

Symptom	Where To Start
No LEDs lit and detector does not respond to traffic.	See <b>Troubleshooting Power Problems</b> . Check for sensitivity set extremely low (0 to 2).
LOOP FAIL indication (LED ON Red or flashing Red at a one Hz rate). Previous LOOP FAIL indication	See <b>Troubleshooting Loop Fail Problems</b> .
(LED flashing three times per second Red) and detector appears to be working correctly.	See <b>Troubleshooting Intermittent Loop Fail Problems</b> .
Detector intermittently stays in the Call state (LED ON Green).	See <b>Troubleshooting Intermittent Detector Lock Ups</b> .

### 8.1 TROUBLESHOOTING POWER PROBLEMS

Do any of the LEDs turn ON (Green) when the detector is powered up and a vehicle is over one of the loops connected to the detector?

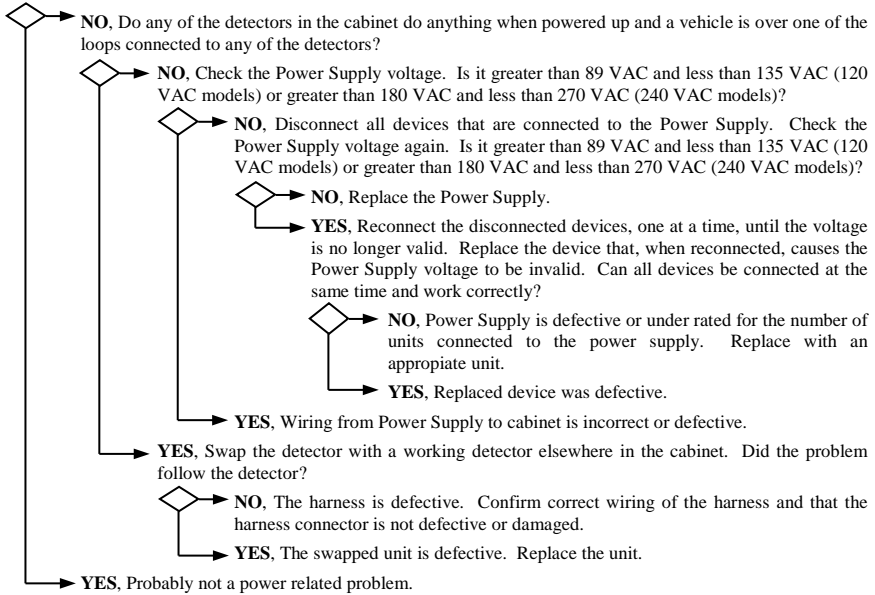

## 8.2 TROUBLESHOOTING LOOP FAIL PROBLEMS

Is one of the four front panel LEDs showing a Loop Failure indication (ON Red or one Hz flash rate Red)?

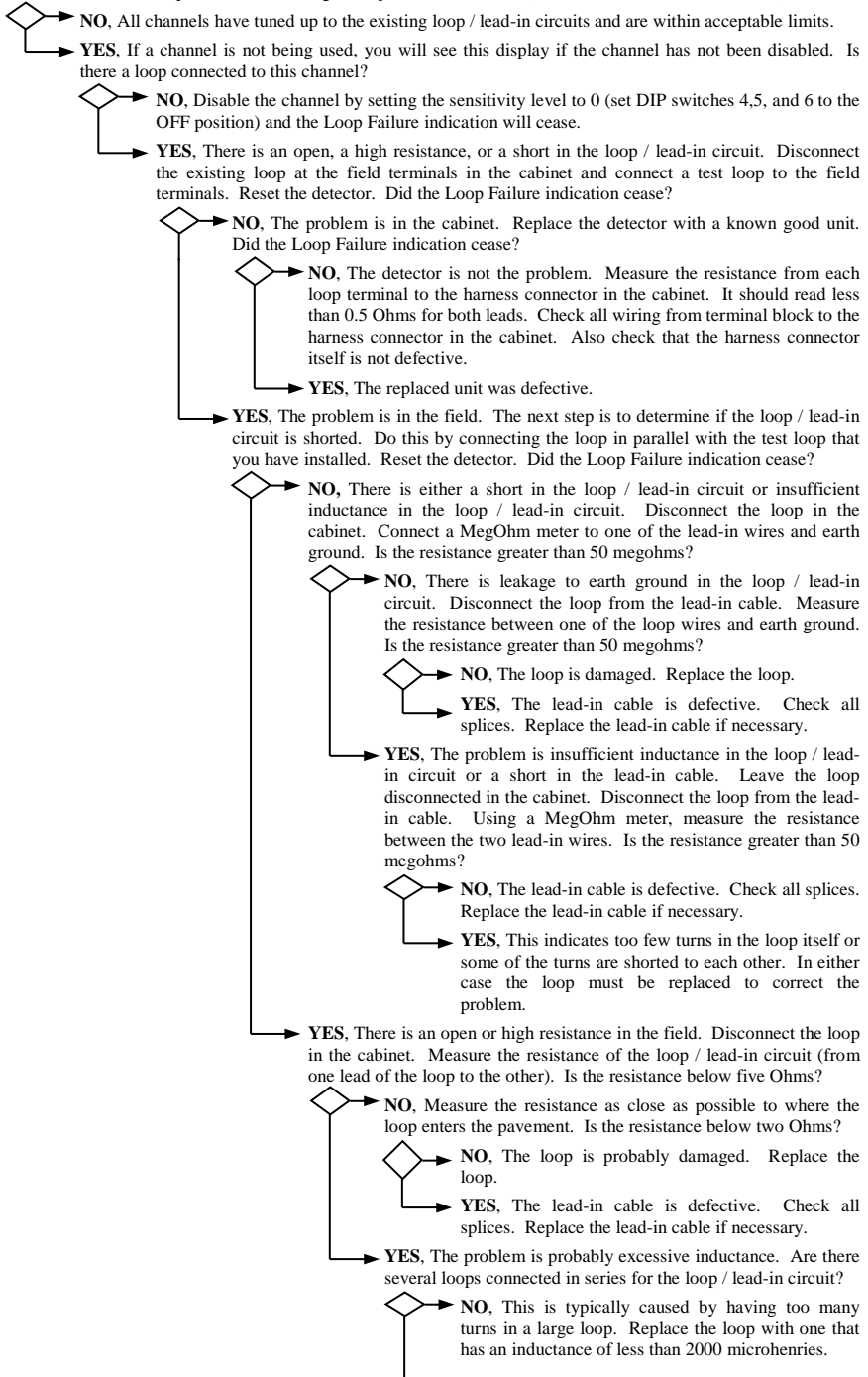

- **YES**. If possible, connecting each loop to its own detector is preferred. Or try a parallel wiring arrangement for the loops if separate detection channels are not possible.

### 8.3 TROUBLESHOOTING INTERMITTENT LOOP FAIL PROBLEMS

Intermittent Loop Fail problems tend to be associated with bad splices in the loop / lead-in circuit, shorts in the loop / lead-in circuit, shorts to earth ground in the loop / lead-in circuit, or loose connections or bad solder joints in the signal cabinet. If you have any splices that are not soldered and sealed with an adhesive heat shrink or epoxy resin, replace the splice with one that is. Using a MegOhm meter, measure the resistance from one of the loop wires to earth ground. It should be greater than 50 megohms. Inspect the loop. Look for exposed wires or debris pressed into the saw cut. Tighten all screw terminals in the signal cabinet that the loop circuit uses. Check solder joints in the loop circuit, especially on the rack itself. Disconnect and reconnect any connector used in the loop circuit and check for loose pins and sockets in these connectors. If your cabinet has lightning or surge suppression devices on the loop inputs in the cabinet, remove or replace them. Check for places in the field where the loop wire or lead-in cable may be pinched or chaffed. Look for wires pinched under junction box covers and where the wire enters a conduit, especially where the loop wire leaves the saw cut and enters a conduit. After checking all of the above items, you could swap out the detector but this type of failure is rarely ever related to the detector.

### 8.4 TROUBLESHOOTING INTERMITTENT DETECTOR LOCK-UPS

Problems of this type tend to be difficult to isolate due to the many possible causes and the short duration of the symptom (usually less than 30 minutes). If the problem occurs more frequently in the morning or when raining, suspect a short to earth ground in the loop / lead-in circuit. This can usually be verified by testing with a MegOhm meter, but not always. Vibration can also be a possible cause. Loop wires may be moving slightly in a conduit due to vibrations from truck traffic. Utility lids in the street near the loop may also be a source of problems. Ensure that lids near a loop are bolted down so that they cannot move. Check that each set of loop wires is twisted together in any pull boxes and that lengths are not excessive. Inspect the loop. Look for exposed wires or debris pressed into the saw cut. Check for places in the field where the loop wire or lead-in cable may be pinched or chaffed. Look for wires pinched under junction box covers and where the wire enters a conduit, especially where the loop wire leaves the saw cut and enters a conduit. **If your cabinet has lightning or surge suppression devices on the loop inputs in the cabinet, remove or replace them.** If you have any splices that are not soldered and sealed with an adhesive heat shrink or epoxy resin, replace the splice with one that is. Solder all crimp connections in the loop circuit. Tighten all screw terminals in the signal cabinet that the loop circuit uses. Check solder joints in the loop circuit, especially on the harness itself. Disconnect and reconnect any connector used in the loop circuit and check for loose pins and sockets in these connectors.

### 8.5 TEST MODE OPERATION

Test Mode uses the microcontroller to verify the proper operation of the detector's controls and indicators (switches and LEDs). Each channel's loop oscillator circuit is also checked to verify the correct frequency in each of the four frequency selections. The frequency portion of the test requires the detector to be connected to a 100 microhenry loop. If an inductance value other than 100 microhenries is used, the frequency test results will be invalid.

**NOTE: The test procedures outlined below should not be performed in an operational traffic signal cabinet.**

#### Test Procedure (Programming DIP switches):

- STEP 1.** Remove power from the detector.
- STEP 2.** Set all front panel Channel 1 Programming DIP switches (S1) to the **OFF** position.
- STEP 3.** Set all front panel Channel 2 Programming DIP switches (S2) to the **OFF** position.
- STEP 4.** Set all front panel Channel 3 Programming DIP switches (S3) to the **OFF** position.
- STEP 5.** Set all front panel Channel 4 Programming DIP switches (S4) to the **OFF** position.
- STEP 6.** Install a two-pin shorting jumper (shunt) to the PC Board mounted header labeled **TEST** (J1) and apply power. The LED indicators should be OFF, all detect outputs should be OFF. **NOTE: To test the frequency range the detector must be connected to a 100 microhenry loop.** The other tests may be performed with loops within the range of 20 to 2000 microhenries.

**STEP 7.** Individually, turn ON switches 6, 5, 4, and 3 of the Channel 1 Programming DIP switch. Turn OFF each switch after verifying the results indicated in the table below.

Switch Label	Switch #	LED Indications and Outputs
SENSE LEVEL 4	6	CHANNEL 1 DETECT / FAIL LED ILLUMINATED - GREEN
SENSE LEVEL 2	5	CHANNEL 1 DETECT / FAIL LED ILLUMINATED - RED
SENSE LEVEL 1	4	CHANNEL 1 DETECT / FAIL LED ILLUMINATED - GREEN
PRES PULS	3	CHANNEL 1 DETECT / FAIL LED ILLUMINATED - RED

**STEP 8.** Individually, turn ON switches 6, 5, 4, and 3 of the Channel 2 Programming DIP switch. Turn OFF each switch after verifying the results indicated in the table below.

Switch Label	Switch #	LED Indications and Outputs
SENSE LEVEL 4	6	CHANNEL 2 DETECT / FAIL LED ILLUMINATED - GREEN
SENSE LEVEL 2	5	CHANNEL 2 DETECT / FAIL LED ILLUMINATED - RED
SENSE LEVEL 1	4	CHANNEL 2 DETECT / FAIL LED ILLUMINATED - GREEN
PRES PULS	3	CHANNEL 2 DETECT / FAIL LED ILLUMINATED - RED

**STEP 9.** Individually, turn ON switches 6, 5, 4, and 3 of the Channel 3 Programming DIP switch. Turn OFF each switch after verifying the results indicated in the table below.

Switch Label	Switch #	LED Indications and Outputs
SENSE LEVEL 4	6	CHANNEL 3 DETECT / FAIL LED ILLUMINATED - GREEN
SENSE LEVEL 2	5	CHANNEL 3 DETECT / FAIL LED ILLUMINATED - RED
SENSE LEVEL 1	4	CHANNEL 3 DETECT / FAIL LED ILLUMINATED - GREEN
PRES PULS	3	CHANNEL 3 DETECT / FAIL LED ILLUMINATED - RED

**STEP 10.** Individually, turn ON switches 6, 5, 4, and 3 of the Channel 4 Programming DIP switch. Turn OFF each switch after verifying the results indicated in the table below.

Switch Label	Switch #	LED Indications and Outputs
SENSE LEVEL 4	6	CHANNEL 4 DETECT / FAIL LED ILLUMINATED - GREEN
SENSE LEVEL 2	5	CHANNEL 4 DETECT / FAIL LED ILLUMINATED - RED
SENSE LEVEL 1	4	CHANNEL 4 DETECT / FAIL LED ILLUMINATED - GREEN
PRES PULS	3	CHANNEL 4 DETECT / FAIL LED ILLUMINATED - RED

**STEP 11.** Remove power from the detector and remove the two-pin shorting jumper from the **TEST** header.

**Test Procedure (Frequency DIP switches):**

- STEP 1.** Remove power from the detector.
- STEP 2.** Set all front panel Channel 1 Programming DIP switches (S1) to the **OFF** position.
- STEP 3.** Set all front panel Channel 2 Programming DIP switches (S2) to the **OFF** position.
- STEP 4.** Set all front panel Channel 3 Programming DIP switches (S3) to the **OFF** position.
- STEP 5.** Set all front panel Channel 4 Programming DIP switches (S4) to the **OFF** position.
- STEP 6.** Install a two-pin shorting jumper (shunt) to the PC Board mounted header labeled **TEST** (J1) and apply power. The LED indicators should be OFF, all detect outputs should be OFF. **NOTE: To test the frequency range the detector must be connected to a 100 microhenry loop.** The other tests may be performed with loops within the range of 20 to 2000 microhenries.
- STEP 7.** Using the two Channel 1 Frequency DIP switches (switches 2 and 1 of the Channel 1 Programming DIP switch), perform the actions and verify the results indicated in the table below.

Switch Label	Switch #	Action	LED Indications and Outputs
FREQ 1	2	TOGGLE ON	CHANNEL 1 DETECT / FAIL LED FLASH - GREEN
FREQ 2	1	TOGGLE ON	CHANNEL 1 DETECT / FAIL LED FLASH - GREEN / RED
FREQ 1	2	TOGGLE OFF	CHANNEL 1 DETECT / FAIL LED FLASH - RED
FREQ 2	1	TOGGLE OFF	CHANNEL 1 DETECT / FAIL LED OFF

**STEP 8.** Using the two Channel 2 Frequency DIP switches (switches 2 and 1 of the Channel 2 Programming DIP switch), perform the actions and verify the results indicated in the table below.

Switch Label	Switch #	Action	LED Indications and Outputs
FREQ 1	2	TOGGLE ON	CHANNEL 2 DETECT / FAIL LED FLASH - GREEN
FREQ 2	1	TOGGLE ON	CHANNEL 2 DETECT / FAIL LED FLASH - GREEN / RED
FREQ 1	2	TOGGLE OFF	CHANNEL 2 DETECT / FAIL LED FLASH - RED
FREQ 2	1	TOGGLE OFF	CHANNEL 2 DETECT / FAIL LED OFF

**STEP 9.** Using the two Channel 3 Frequency DIP switches (switches 2 and 1 of the Channel 3 Programming DIP switch), perform the actions and verify the results indicated in the table below.

Switch Label	Switch #	Action	LED Indications and Outputs
FREQ 1	2	TOGGLE ON	CHANNEL 3 DETECT / FAIL LED FLASH - GREEN
FREQ 2	1	TOGGLE ON	CHANNEL 3 DETECT / FAIL LED FLASH - GREEN / RED
FREQ 1	2	TOGGLE OFF	CHANNEL 3 DETECT / FAIL LED FLASH - RED
FREQ 2	1	TOGGLE OFF	CHANNEL 3 DETECT / FAIL LED OFF

**STEP 10.** Using the two Channel 4 Frequency DIP switches (switches 2 and 1 of the Channel 4 Programming DIP switch), perform the actions and verify the results indicated in the table below.

Switch Label	Switch #	Action	LED Indications and Outputs
FREQ 1	2	TOGGLE ON	CHANNEL 4 DETECT / FAIL LED FLASH - GREEN
FREQ 2	1	TOGGLE ON	CHANNEL 4 DETECT / FAIL LED FLASH - GREEN / RED
FREQ 1	2	TOGGLE OFF	CHANNEL 4 DETECT / FAIL LED FLASH - RED
FREQ 2	1	TOGGLE OFF	CHANNEL 4 DETECT / FAIL LED OFF

**STEP 11.** Remove power from the detector and remove the two-pin shorting jumper from the **TEST** header.

An LED indication different than the ones described for each switch setting indicates the loop frequency is out of tolerance. Verify that the loop test coil has an inductance of 100 microhenries. If the test loop measures 100 microhenries the detector module should be serviced.

**Test Procedure (Front Panel Buzzer switch):**

**STEP 1.** Remove power from the detector.

**STEP 2.** Refer to the table in Section 3.5 and set all front panel Channel 1, Channel 2, Channel 3, and Channel 4 Programming DIP switches (S1, S2, S3, and S4) to their default positions.

**STEP 3.** Apply power. The LED indicators should be OFF, all detect outputs should be OFF. **NOTE: To test the frequency range the detector must be connected to a 100 microhenry loop.** The other tests may be performed with loops within the range of 20 to 2000 microhenries.

**STEP 4.** Press the Front Panel mounted switch labeled **BUZZER**. The buzzer should sound once (50 ms).

**STEP 5.** Perform the actions and verify the results indicated in the table below.

Action	LED Indications and Outputs
INPUT CALL CHANNEL 1	<ul style="list-style-type: none"> <li>CHANNEL 1 DETECT / FAIL LED ILLUMINATED - ORANGE</li> <li>BUZZER SOUNDS</li> </ul>
REMOVE CALL CHANNEL 1	<ul style="list-style-type: none"> <li>CHANNEL 1 DETECT / FAIL LED OFF</li> <li>BUZZER OFF</li> </ul>

**STEP 6.** Press the Front Panel mounted switch labeled **BUZZER**. The buzzer should sound twice (50 ms).

**STEP 7.** Perform the actions and verify the results indicated in the table below.

Action	LED Indications and Outputs
INPUT CALL CHANNEL 2	<ul style="list-style-type: none"> <li>CHANNEL 2 DETECT / FAIL LED ILLUMINATED - ORANGE</li> <li>BUZZER SOUNDS</li> </ul>
REMOVE CALL CHANNEL 2	<ul style="list-style-type: none"> <li>CHANNEL 2 DETECT / FAIL LED OFF</li> <li>BUZZER OFF</li> </ul>

**STEP 8.** Press the Front Panel mounted switch labeled **BUZZER**. The buzzer should sound three times (50 ms).

**STEP 9.** Perform the actions and verify the results indicated in the table below.

Action	LED Indications and Outputs
INPUT CALL CHANNEL 3	<ul style="list-style-type: none"> <li>CHANNEL 3 DETECT / FAIL LED ILLUMINATED - ORANGE</li> <li>BUZZER SOUNDS</li> </ul>
REMOVE CALL CHANNEL 3	<ul style="list-style-type: none"> <li>CHANNEL 3 DETECT / FAIL LED OFF</li> <li>BUZZER OFF</li> </ul>

**STEP 10.** Press the Front Panel mounted switch labeled **BUZZER**. The buzzer should sound four times (50 ms).

**STEP 11.** Perform the actions and verify the results indicated in the table below.

Action	LED Indications and Outputs
INPUT CALL CHANNEL 4	<ul style="list-style-type: none"> <li>• CHANNEL 4 DETECT / FAIL LED ILLUMINATED - ORANGE</li> <li>• BUZZER SOUNDS</li> </ul>
REMOVE CALL CHANNEL 4	<ul style="list-style-type: none"> <li>• CHANNEL 4 DETECT / FAIL LED OFF</li> <li>• BUZZER OFF</li> </ul>

**STEP 12.** Press the Front Panel mounted switch labeled **BUZZER**. The buzzer should sound once (250 ms).

**STEP 13.** Remove power from the detector.

**Test Procedure (Front Panel Reset switch):**

**STEP 1.** Remove power from the detector.

**STEP 2.** Refer to the table in Section 3.5 and set all front panel Channel 1, Channel 2, Channel 3, and Channel 4 Programming DIP switches (S1, S2, S3, and S4) to their default positions.

**STEP 3.** Apply power. The LED indicators should be OFF, all detect outputs should be OFF. **NOTE: To test the frequency range the detector must be connected to a 100 microhenry loop.** The other tests may be performed with loops within the range of 20 to 2000 microhenries.

**STEP 4.** Apply power. The LED indicators should be OFF, all detect outputs should be OFF. **NOTE: To test the frequency range the detector must be connected to a 100 microhenry loop.** The other tests may be performed with loops within the range of 20 to 2000 microhenries.

**STEP 5.** Perform the actions and verify the results indicated in the table below. **NOTE:** Unless otherwise noted, references to switches, buttons, or inputs in the table correspond to labels on test equipment supplied by Reno A & E.

Switch / Button / Input	Action	LED Indications and Outputs
DETECTOR <b>RESET</b> BUTTON	PRESS AND HOLD	<ul style="list-style-type: none"> <li>• DETECTOR CHANNEL 1 OUTPUT ON</li> <li>• TEST BOX CHANNEL 1 DETECT LED ON</li> <li>• DETECTOR CHANNEL 2 OUTPUT ON</li> <li>• TEST BOX CHANNEL 2 DETECT LED ON</li> <li>• DETECTOR CHANNEL 3 OUTPUT ON</li> <li>• TEST BOX CHANNEL 3 DETECT LED ON</li> <li>• DETECTOR CHANNEL 4 OUTPUT ON</li> <li>• TEST BOX CHANNEL 4 DETECT LED ON</li> </ul>
DETECTOR <b>RESET</b> BUTTON	RELEASE	<ul style="list-style-type: none"> <li>• DETECTOR CHANNEL 1 OUTPUT OFF</li> <li>• TEST BOX CHANNEL 1 DETECT LED OFF</li> <li>• DETECTOR CHANNEL 2 OUTPUT OFF</li> <li>• TEST BOX CHANNEL 2 DETECT LED OFF</li> <li>• DETECTOR CHANNEL 3 OUTPUT OFF</li> <li>• TEST BOX CHANNEL 3 DETECT LED OFF</li> <li>• DETECTOR CHANNEL 4 OUTPUT OFF</li> <li>• TEST BOX CHANNEL 4 DETECT LED OFF</li> </ul>

**STEP 6.** Remove power from the detector.

## 8.6 THINGS TO KNOW ABOUT LOOPS

Always use a wire with cross-linked Polyethylene insulation (insulation type XLPE) for loop wire.

Typical sensing height is  $\frac{2}{3}$  of the shortest leg of a loop. Therefore, a 6' x 6' loop will have a detection height of 4'.

The inductance of a conventional four-sided loop can be estimated using the formula:

$$L = P \times (T^2 + T) / 4$$

Where: L = Loop Inductance in microhenries  
P = Loop Perimeter in feet  
T = Number of Turns of Wire.

Therefore, a 6' by 6' loop with 3 turns would have an inductance of:

$$\begin{aligned} L &= (6 + 6 + 6 + 6) \times (3^2 + 3) / 4 \\ L &= 24 \times (9 + 3) / 4 \\ L &= 24 \times 12 / 4 \\ L &= 24 \times 3 \\ L &= 72 \text{ microhenries.} \end{aligned}$$

The inductance of a Quadropole™ loop can be estimated using the formula:

$$L = [P \times (T^2 + T) / 4] + [CL \times (T^2 + T) / 4]$$

Where: L = Loop Inductance in microhenries  
P = Loop Perimeter in feet  
T = Number of Turns of Wire  
CL = Length of Center Leg in feet.

Therefore, a 6' by 50' loop with a 2-4-2 configuration would have an inductance of:

$$\begin{aligned} L &= [(6 + 50 + 6 + 50) \times (2^2 + 2) / 4] + [50 \times (4^2 + 4) / 4] \\ L &= [112 \times (4 + 2) / 4] + [50 \times (16 + 4) / 4] \\ L &= (112 \times 6 / 4) + (50 \times 20 / 4) \\ L &= (112 \times 1.5) + (50 \times 5) \\ L &= 168 + 250 \\ L &= 418 \text{ microhenries.} \end{aligned}$$

Loop Feeder cable typically adds 0.22 microhenries of inductance per foot of cable.

Total inductance of loops connected in series:

$$L_{TOTAL} = L_1 + L_2 + L_3 + \dots + L_N.$$

Total inductance of loops connected in parallel:

$$L_{TOTAL} = 1 / [(1 / L_1) + (1 / L_2) + (1 / L_3) + \dots + (1 / L_N)].$$